

A40-10KSI

PISTON ACCUMULATORS

Product Specifications

Outside Diameter	7.25 in (184 mm)
Housing and End Cap Material	Steel
Standard Fluid Port	9/16 MP*
Piston Material	Aluminum
Sealing Material	Buna-N
Back-Up/Wear Ring Material	Teflon
Gas Valve Material	Stainless Steel
Max Working Pressure	10,000 psi (689 bar)
Proof Pressure	13,000 psi (896 bar)
Temperature Range	20°F to 200°F (-6°C to 93°C)**
Seal Kit Part Number (Buna)	TBD

*Custom fluid ports and mounting configurations available.

**Charpy Testing Required

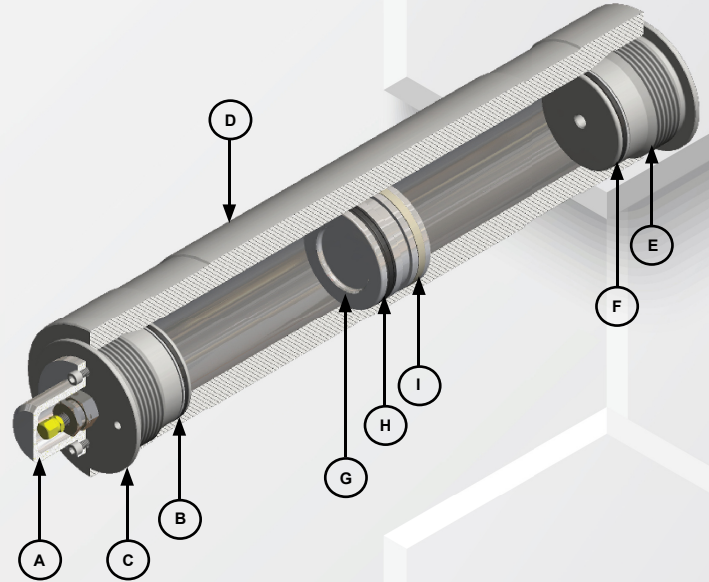

Parts Breakdown

ITEM	DESCRIPTION	QTY
A	Air Valve Cover	1
B	Back-Up Ring	2
C	Gas Cap	1
D	Housing	1
E	Oil Cap	1
F	O-Ring	2
G	Piston	1
H	T-Seal	1
I	Wear Strip	1

NOTE: Nameplate included but not shown.

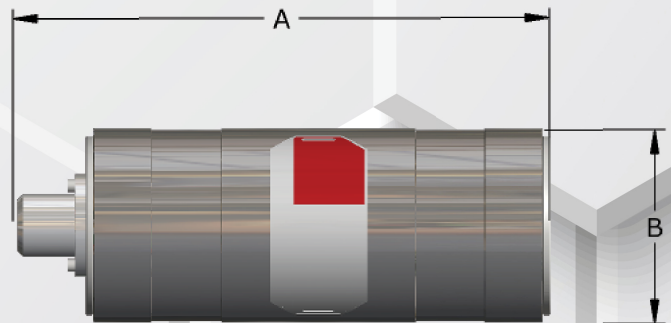

Note: Above drawings not to scale.

Model Variations

Model No.	Nominal Size		Dim A*		Dim B		Weight	
	gal	liter	in	mm	in	mm	lbs	kg
A40-0058-10K-B-09MP	1/4	0.95	14.75	375	7.25	184	150	68
A40-0116-10K-B-09MP	1/2	1.89	19.25	489	7.25	184	187	84
A40-0231-10K-B-09MP	1	3.78	28.38	721	7.25	184	261	118
A40-0462-10K-B-09MP	2	7.57	46.75	1187	7.25	184	411	186

*Length shown includes 1.656" for gas valve

Also Available in Stainless Steel and with ASME Approval